

## ENGINE

Model	Isuzu AM-4HK1X Tier 4 Interim Certified (Cooled EGR)
Fuel	Requires ultra low-sulfur fuel B5 biodiesel tolerant
Type	Water-cooled, 4-cycle, high pressure common rail system. Turbo-charged with air cooled intercooler, DPD system
Cylinders	4-cylinder in-line
Displacement	317 in <sup>3</sup> (5.2 L)
Bore / Stroke	4.53 in x 4.92 in (115 mm x 125 mm)
Fuel injection	Direct injection (electronic)
Fuel filter	Replaceable, full flow spin-on cartridge
Air filter	Dry type element w/ warning restriction indicator
Oil filter	Replaceable, full flow spin-on cartridge
Engine oil operating angle ratings:	
Side-to-side	Rated 35° slope
Fore and aft	Rated 35° slope
Net horsepower @ 1800 RPM—SAE J1349:	160 hp (119.3 kW)
Net maximum torque @ 1500 RPM—SAE J1349:	458 lb-ft (621 N-m)
Cooling	110° to -13°F (43° to -25°C) at 55% concentration
Oil	Requires low-ash oil (CJ-4)

## POWERTRAIN

Travel control	Dual stage relief/ counter balance design
Brakes	Mechanical disc
Service brakes	SAHR disc (each motor)
Two speed travel:	
Max. high speed	3.1 mph (5.0 kph)
Max. low speed	2.1 mph (3.2 kph)
Automatic downshift	
Drawbar pull	45,200 lbf (201 kN)
Gradeability	70% (35° slope)

## ELECTRICAL

Voltage	24 Volts
Alternator rating	50 amp
Batteries	2 x 12 Volt
Battery Reserve Capacity	92 Ah / 5 hour
Work lights (2)	24 Volt / 70 watt (1 x boom; 1 x upper)

## OPERATOR ENVIRONMENT

Air-conditioner output	18,100 BTU/hr
Heater output	20,150 BTU/hr
Sound level—ISO6395:	
Inside cab	70 dBa
Electrical outlet	12 Volt
Cab interior light (1)	10 watt
Rear-view camera (1)	Standard
Seat	Air-suspension

## OPERATING WEIGHT

Operating weight	56,029 lb (25 400 kg)
w/ shoes	31.5 in (800 mm)
w/ boom	18 ft 8 in (5.70 m)
w/ arm	9 ft 8 in (2.94 m)
w/ bucket	1,705 lb (794 kg)
w/ counterweight	17,000 lb (7700 kg)
w/ operator / full fuel / standard equipment	

## HYDRAULICS

System design	Open center
Main pumps	Two variable displacement/ axial pistons
Max. rated flow	2 x 55.7 gpm (2 x 211 L/min)
System pressures:	
Boom, arm & bucket w/ power boost	4,970 psi (350 bar) 5,330 psi (375 bar)
Travel circuits	4,970 psi (350 bar)
Swing circuits	4,260 psi (300 bar)
Pilot pump	1 x gear design
Max. capacity	4.8 gpm (18 L/min)
Controls	With boom/arm holding valve
Right track travel, bucket, boom and arm acceleration.	Four-spool section
Left track travel, auxiliary, swing, boom acceleration	Five-spool section
Work Mode Selections	SP: Speed priority H: Heavy duty A: Automatic
Swing motor	Fixed displacement axial piston
Swing final drive	Planetary gear reduction
Travel motor	Two-speed independent travel/axial piston
Boom cylinders	Two (2)
Cylinder bore	4.7 in (120 mm)
Cylinder rod diameter	3.3 in (85 mm)
Cylinder stroke	53.5 in (1370 mm)

## HYDRAULICS (CONT.)

Arm cylinder	One (1)
Cylinder bore	5.5 in (140 mm)
Cylinder rod diameter	3.9 in (100 mm)
Cylinder stroke	57.5 in (1460 mm)
Bucket cylinder	One (1)
Cylinder bore	4.7 in (120 mm)
Cylinder rod diameter	3.3 in (85 mm)
Cylinder stroke	39.8 in (1010 mm)

## SERVICE CAPACITY

Fuel tank	85 gal (320 L)
Hydraulic system	67 gal (252 L)
Hydraulic tank	30 gal (114 L)
Engine oil w/ filter	6.1 gal (23.1 L)
Swing drive	5.3 qt (5.0 L)
Final drive (each side)	5.3 qt (5.0 L)
Cooling system	8.2 gal (30.9 L)

## OTHER SPECIFICATIONS

Bucket digging force*	31,920 lbf (142 kN)
w/ Auto Power-Boost	34,170 lbf (152 kN)
*Digging force ratings based on ISO6015	
Swing speed	0 – 11.8 RPM
Swing torque	47,200 lb-ft (64 000 N-m)
Swing brake	Mechanical disc
<b>Undercarriage:</b>	
Length	14 ft 8 in (4.47 m)
Track gauge	7 ft 10 in (2.4 m)
Carrier rollers	2 per side
Track rollers	8 per side
Shoes—triple grouser	49 per side
Shoe width (std.)	31.5 in (800 mm)
Link pitch	7.5 in (190 mm)

Track:	
Chain	Grease lubricated/strutted
Guides	Single
Adjustment	Hydraulic

Ground pressure @ std. operating weight w/ 31.5 in (800 mm) triple semi-grouser shoes:	5.8 psi (.40 bar)
---	-------------------

## CX235C SR LIFT CAPACITIES

7 ft 10 in (2.40 m) Arm Lift capacities calculated using a 1,550 lb (703 kg) bucket, 17,000 lb (7700 kg) counterweight.

Load (Lift Point) Height	5 ft (1.5 m)		10 ft (3 m)		15 ft (4.5 m)		20 ft (6 m)		25 ft (7.5 m)		MAXIMUM REACH		
	END	SIDE	END	SIDE	END	SIDE	END	SIDE	END	SIDE	@	END	SIDE
+30 ft (9 m)					10,000 lb* (4536 kg)*	10,000 lb* (4536 kg)*					16 ft 8 in (5.08 m)	8,500 lb* (3856 kg)*	8,500 lb* (3856 kg)*
+25 ft (7.5 m)					8,050 lb* (3651 kg)*	8,050 lb* (3651 kg)*	9,800 lb* (4445 kg)*	9,800 lb* (4445 kg)*			22 ft 11 in (6.98 m)	7,300 lb* (3311 kg)*	7,300 lb* (3311 kg)*
+20 ft (6 m)					11,300 lb* (5126 kg)*	11,300 lb* (5126 kg)*	10,750 lb* (4876 kg)*	10,750 lb* (4876 kg)*	9,800 lb* (4445 kg)*	8,200 lb (3719 kg)	26 ft 5 in (8.05 m)	6,900 lb* (3130 kg)*	6,900 lb* (3130 kg)*
+15 ft (4.5 m)			18,000 lb* (8165 kg)*	18,000 lb* (8165 kg)*	14,350 lb* (6509 kg)*	14,350 lb* (6509 kg)*	11,900 lb* (5398 kg)*	11,600 lb (5262 kg)	10,750 lb* (4876 kg)*	8,050 lb (3651 kg)	28 ft 7 in (8.71 m)	6,850 lb* (3107 kg)*	6,300 lb (2858 kg)
+10 ft (3 m)			26,800 lb* (12 156 kg)*	26,800 lb* (12 156 kg)*	18,500 lb* (8391 kg)*	17,350 lb* (7870 kg)*	13,900 lb* (6305 kg)*	11,150 lb (5058 kg)	11,650 lb* (5284 kg)*	7,800 lb (3538 kg)	29 ft 6 in (8.99 m)	7,050 lb* (3198 kg)*	5,800 lb (2631 kg)
+5 ft (1.5 m)					21,650 lb* (9820 kg)*	16,300 lb (7394 kg)	15,650 lb* (7099 kg)*	10,600 lb (4808 kg)	12,000 lb (5443 kg)	7,500 lb (3402 kg)	29 ft 6 in (8.99 m)	7,500 lb* (3402 kg)*	5,700 lb (2585 kg)
Ground- line			17,500 lb* (7938 kg)*	17,500 lb* (7938 kg)*	22,850 lb* (10 365 kg)*	15,650 lb (7099 kg)	16,550 lb* (7507 kg)*	10,200 lb (4627 kg)	11,800 lb (5352 kg)	7,300 lb (3311 kg)	28 ft 7 in (8.71 m)	8,250 lb* (3742 kg)*	5,950 lb (2699 kg)
-5 ft (-1.5 m)	18,100 lb* (8210 kg)*	18,100 lb* (8210 kg)*	25,650 lb* (11 635 kg)*	25,650 lb* (11 635 kg)*	22,600 lb* (10 251 kg)*	15,550 lb (7053 kg)	16,500 lb (7484 kg)	10,100 lb (4581 kg)	11,750 lb (5330 kg)	7,250 lb (3289 kg)	26 ft 9 in (8.15 m)	9,700 lb* (4400 kg)*	6,600 lb (2994 kg)
-10 ft (-3 m)	25,300 lb* (11 476 kg)*	25,300 lb* (11 476 kg)*	29,950 lb* (13 585 kg)*	29,950 lb* (13 585 kg)*	20,950 lb* (9503 kg)*	15,800 lb (7167 kg)	15,300 lb* (6940 kg)*	10,300 lb (4672 kg)			23 ft 8 in (7.21 m)	11,350 lb* (5148 kg)*	8,000 lb (3629 kg)
-15 ft (-4.5 m)			23,450 lb* (10 637 kg)*	23,450 lb* (10 637 kg)*	16,550 lb* (7507 kg)*	16,050 lb (7280 kg)					19 ft 0 in (5.79 m)	11,150 lb* (5058 kg)*	11,150 lb* (5058 kg)*

9 ft 8 in (2.94 m) Arm Lift capacities calculated using a 1,450 lb (658 kg) bucket, 17,000 lb (7700 kg) counterweight.

Load (Lift Point) Height	5 ft (1.5 m)		10 ft (3 m)		15 ft (4.5 m)		20 ft (6 m)		25 ft (7.5 m)		30 ft (9 m)		MAXIMUM REACH		
	END	SIDE	END	SIDE	END	SIDE	END	SIDE	END	SIDE	END	SIDE	@	END	SIDE
+30 ft (9 m)					4,700 lb* (2132 kg)*	4,700 lb* (2132 kg)*							19 ft 7 in (5.97 m)	5,650 lb* (2563 kg)*	5,650 lb* (2563 kg)*
+25 ft (7.5 m)							8,850 lb* (4014 kg)*	8,850 lb* (4014 kg)*					25 ft 0 in (7.62 m)	4,950 lb* (2245 kg)*	4,950 lb* (2245 kg)*
+20 ft (6 m)							9,850 lb* (4468 kg)*	9,850 lb* (4468 kg)*	8,950 lb* (4060 kg)*	8,450 lb (3833 kg)	5,300 lb* (2404 kg)*	5,300 lb* (2404 kg)*	28 ft 3 in (8.61 m)	4,700 lb* (2132 kg)*	4,700 lb* (2132 kg)*
+15 ft (4.5 m)			10,950 lb* (4967 kg)*	10,950 lb* (4967 kg)*	12,300 lb* (5579 kg)*	12,300 lb* (5579 kg)*	10,950 lb* (4967 kg)*	10,950 lb* (4967 kg)*	10,050 lb* (4559 kg)*	8,250 lb (3742 kg)	7,950 lb* (3606 kg)*	5,800 lb (2631 kg)	30 ft 2 in (9.19 m)	4,650 lb* (2109 kg)*	4,650 lb* (2109 kg)*
+10 ft (3 m)			23,800 lb* (10 795 kg)*	23,800 lb* (10 795 kg)*	17,100 lb* (7756 kg)*	17,100 lb* (7756 kg)*	13,200 lb* (5987 kg)*	11,400 lb (5171 kg)	11,100 lb* (5035 kg)*	7,950 lb (3606 kg)	8,700 lb* (3946 kg)*	5,650 lb (2563 kg)	31 ft 1 in (9.47 m)	4,850 lb* (2200 kg)*	4,850 lb* (2200 kg)*
+5 ft (1.5 m)			21,000 lb* (9525 kg)*	21,000 lb* (9525 kg)*	20,850 lb* (9457 kg)*	16,700 lb (7575 kg)	15,150 lb* (6872 kg)*	10,800 lb (4899 kg)	12,100 lb* (5488 kg)*	7,650 lb (3470 kg)	6,800 lb* (3084 kg)*	5,550 lb (2517 kg)	31 ft 1 in (9.47 m)	5,150 lb* (2336 kg)*	5,150 lb* (2336 kg)*
Ground- line	16,250 lb* (7371 kg)*	16,250 lb* (7371 kg)*	19,400 lb* (8800 kg)*	19,400 lb* (8800 kg)*	22,750 lb* (10 319 kg)*	15,900 lb (7212 kg)	16,400 lb* (7439 kg)*	10,350 lb (4695 kg)	11,900 lb (5398 kg)	7,400 lb (3357 kg)			30 ft 3 in (9.22 m)	5,700 lb* (2585 kg)*	5,500 lb (2495 kg)
-5 ft (-1.5 m)	22,350 lb* (10 138 kg)*	22,350 lb* (10 138 kg)*	24,800 lb* (11 249 kg)*	24,800 lb* (11 249 kg)*	22,850 lb* (10 365 kg)*	15,600 lb (7076 kg)	16,550 lb (7507 kg)	10,150 lb (4604 kg)	11,750 lb (5330 kg)	7,300 lb (3311 kg)			28 ft 6 in (8.69 m)	6,650 lb* (3016 kg)*	6,000 lb (2722 kg)
-10 ft (-3 m)	32,300 lb* (14 651 kg)*	32,300 lb* (14 651 kg)*	32,050 lb* (14 538 kg)*	30,800 lb (13 971 kg)	21,850 lb* (9911 kg)*	15,750 lb (7144 kg)	16,000 lb* (7257 kg)*	10,200 lb (4627 kg)	11,650 lb* (5284 kg)*	7,450 lb (3379 kg)			25 ft 8 in (7.82 m)	8,400 lb* (3810 kg)*	7,100 lb (3221 kg)
-15 ft (-4.5 m)			26,700 lb* (12 111 kg)*	26,700 lb* (12 111 kg)*	18,650 lb* (8459 kg)*	16,150 lb (7326 kg)	13,050 lb* (5919 kg)*	10,600 lb (4808 kg)					21 ft 4 in (6.50 m)	11,050 lb* (5012 kg)*	9,500 lb (4309 kg)

NOTE: \*Lift capacities do not exceed 75% of the minimum tipping load or 87% of the hydraulic lift capacity.  
Capacities that are marked with an asterisk are hydraulic limited.

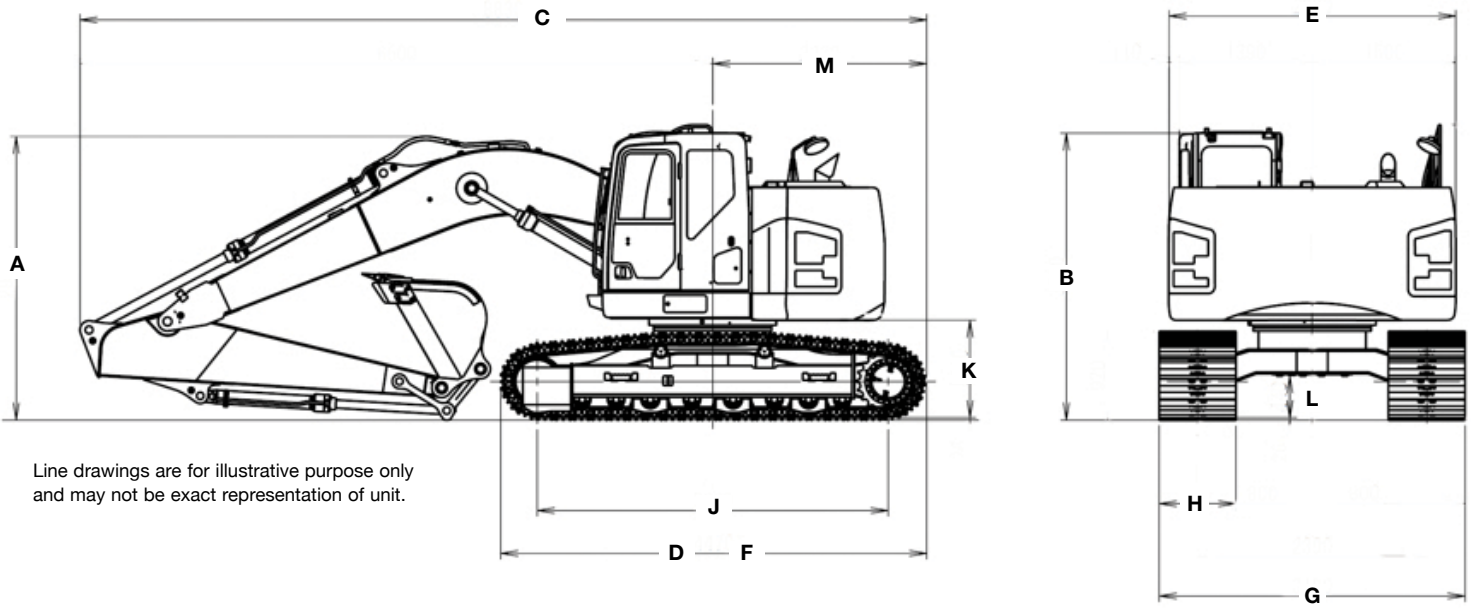

## DIMENSIONS

	9 ft 8 in (2.94 m) Arm	7 ft 10 in (2.40 m) Arm
<b>A.</b> Overall height (w/ attachment)	10 ft 1 in (3.09 m)	10 ft 5 in (3.18 m)
<b>B.</b> Cab height	9 ft 8 in (3.00 m)	9 ft 8 in (3.00 m)
<b>C.</b> Overall length (w/ attachment)	28 ft 10 in (8.83 m)	29 ft 3 in (8.92 m)
<b>D.</b> Overall length (w/o attachment)	14 ft 7 in (4.96 m)	14 ft 7 in (4.96 m)
<b>E.</b> Width of upperstructure	9 ft 8 in (2.99 m)	9 ft 8 in (2.99 m)
<b>F.</b> Track overall length	14 ft 7 in (4.47 m)	14 ft 7 in (4.47 m)
<b>G.</b> Track overall width w/ 31.5 in (800 mm) shoes	10 ft 5 in (3.19 m)	10 ft 5 in (3.19 m)
<b>H.</b> Track shoe width	31.5 in (800 mm)	31.5 in (800 mm)
<b>J.</b> Center to center (idler to sprocket)	12 ft 0 in (3.66 m)	12 ft 0 in (3.66 m)
<b>K.</b> Upperstructure ground clearance	3 ft 4 in (1.02 m)	3 ft 4 in (1.02 m)
<b>L.</b> Minimum ground clearance	17 in (0.44 m)	17 in (0.44 m)
<b>M.</b> Rear tail swing radius	5 ft 9 in (1.79 m)	5 ft 9 in (1.79 m)
Operating weight*	56,029 lb (25 400 kg)	55,492 lb (25 171 kg)
Ground pressure	5.8 psi (.40 bar)	5.8 psi (.40 bar)

NOTE: \*With 31.5 in (800 mm) track shoe, 1,550 lb (703 kg) bucket, 165 lb (75 kg) operator, full fuel and standard equipment.

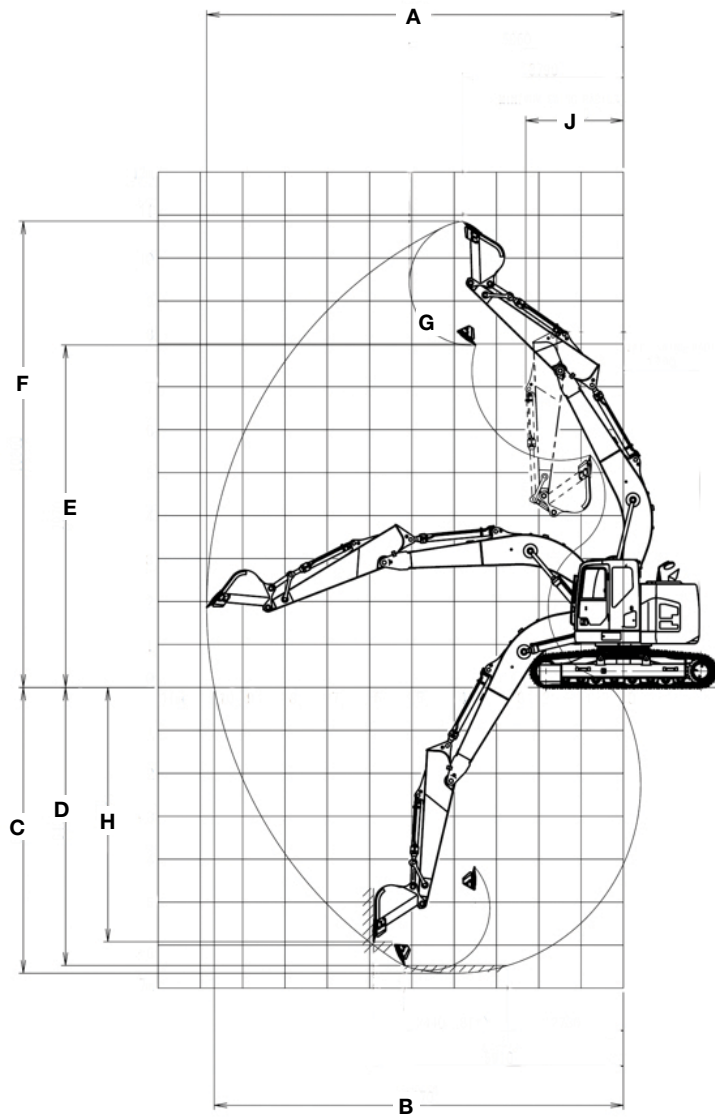

## PERFORMANCE SPECS

	9 ft 8 in (2.94 m) Arm	7 ft 10 in (2.40 m) Arm
<b>A.</b> Maximum dig radius	32 ft 3 in (9.85 m)	30 ft 7 in (9.37 m)
<b>B.</b> Maximum dig radius at groundline	31 ft 7 in (9.67 m)	30 ft 1 in (9.18 m)
<b>C.</b> Maximum dig depth	21 ft 8 in (6.65 m)	20 ft 1 in (6.12 m)
<b>D.</b> Dig depth—8 ft 0 in (2.44 m) level bottom	21 ft 3 in (6.48 m)	19 ft 4 in (5.91 m)
<b>E.</b> Dump height	26 ft 2 in (7.97 m)	25 ft 0 in (7.63 m)
<b>F.</b> Maximum reach height	35 ft 6 in (10.86 m)	34 ft 5 in (10.52 m)
<b>G.</b> Bucket rotation	177°	177°
<b>H.</b> Maximum vertical wall dig depth	19 ft 4 in (5.92 m)	17 ft 10 in (5.48 m)
<b>J.</b> Minimum swing radius	7 ft 7 in (2.31 m)	8 ft 4 in (2.55 m)
Arm digging force:		
Standard	23,160 lb (103 kN)	27,650 lb (123 kN)
Power Boost	24,730 lb (110 kN)	29,670 lb (132 kN)
Bucket digging force:		
Standard	31,920 lb (142 kN)	31,920 lb (142 kN)
Power Boost	34,170 lb (152 kN)	34,170 lb (152 kN)

## STANDARD EQUIPMENT

### ENGINE

Isuzu four-cylinder turbo-charged diesel  
Tier 4 Interim Certified (CEGR)  
Electronic fuel injection  
High pressure common rail system  
Diesel Particulate Defuser System (DPD)  
Neutral safety start  
Auto-engine warm up  
Glow-plug pre-heat  
EPF (Engine Protection Feature)  
Dual-stage fuel filtration  
Dual element air filter  
Remote oil filter  
Green plug oil drain  
500-hour engine oil change interval  
24-volt system  
Requires CJ-4 engine oil  
Requires ultra-low sulfur fuel

### FUEL ECONOMY SYSTEMS

Engine Idle/Fuel Economy System:  
Auto-idle  
One-touch idle  
Idle shut-down  
BEC—Boom Economy Control  
AEC—Auto Economy Control  
SWC—Swing Relief Control  
SSC—Spool Stroke Control

### HYDRAULICS

Auto power boost  
Auto swing priority  
Auto travel speed change  
Selectable work modes  
ISO pattern controls  
Pre-set auxiliary pump settings

## OPTIONAL EQUIPMENT

### HYDRAULICS

Auxiliary hydraulics:  
Single acting/joystick activated  
Double acting/joystick activated  
Multi-function/joystick activated  
Secondary low-flow/joystick activated

### ATTACHMENTS

Arm—7 ft 10 in (2.4 m)  
Coupler / Case multi-pin grabber  
Buckets:  
Heavy-duty  
Extreme-duty  
Load holding control  
Free swing (order kit through Service Parts)  
Hose Burst Check Valve (HBCV)

### HYDRAULICS (CONT.)

Auxiliary valve  
Auxiliary pipe brackets  
5,000-hour hydraulic oil change interval  
1,000-hour hydraulic filter change interval  
SAHR brake

### UPPERSTRUCTURE

Right and left side mirrors  
Isolation mounted cab (fluid and spring)  
Common key vandal locks  
Upper mounted work light (70 watt)  
Swivel guard belly pan

### ATTACHMENTS

Boom—18 ft 8 in (5.7 m)  
Arm—9 ft 8 in (2.94 m)  
Heavy-duty bucket linkage  
Boom mounted work light (70 watt)  
Auxiliary pipe brackets  
Centralized grease fittings  
Attachment cushion valve  
Arm and boom regeneration

### OPERATOR STATION

ROPS protection  
FOPS cab top guard (Level 1)  
Pressurized cab  
One-touch lock front window  
AC/heat/defrost w/ auto climate control  
Color monitor—7 in (180 mm)  
Interior dome light  
Air-suspension seat (cloth)  
Seatbelt—3 in (76 mm)  
Adjustable armrests

### OPERATOR STATION (CONT.)

Tilting consoles—4-position  
Low-effort joystick controls  
Sliding cockpit—7 in (180 mm)  
Controls pre-wired for auxiliary  
Straight travel  
AM/FM radio w/ antenna and 2 speakers  
Aux-in port for personal electronics  
Rear-view camera  
Anti-theft system (start code system)  
Rubber floor mat  
12-volt electric outlet  
24-volt cigarette lighter  
External rear view mirrors  
Windshield wiper / washer  
Clear (polycarbonate) roof window w/ sunshade  
Cup holder  
Storage compartments  
Warm / cool storage compartment  
On-board diagnostic system  
Travel alarm with cancel switch  
One key start and lock-up

### UNDERCARRIAGE

31.5 in (800 mm) steel shoes, triple semi-grouser  
Full overlap turntable bearing tub  
Single track chain guides  
Hydraulic track adjustment  
X-pattern carbody

### OPERATOR STATION

Control pattern selector  
FOPS cab top guard (Level 2)  
Front grill guard—2 x 2 screen mesh  
Front rock guard—vertical bars  
(two piece) / OPG 1  
Front rock guard—vertical bars  
(fixed/one piece) / OPG 2  
Vandal guard  
Rain deflector  
Sun visor  
Side-view camera

### UNDERCARRIAGE

23.6 in (600 mm) rubber shoes  
23.6 in (600 mm) steel shoes, triple semi-grouser  
27.6 in (700 mm) steel shoes, triple semi-grouser

## BUCKETS

Application	Width	SAE Heaped Capacity
General Purpose	24 in to 48 in (0.61 m to 1.22 m)	0.65 yd <sup>3</sup> to 1.53 yd <sup>3</sup> (0.50 m <sup>3</sup> to 1.17 m <sup>3</sup> )
Heavy-duty	24 in to 48 in (0.61 m to 1.22 m)	0.64 yd <sup>3</sup> to 1.51 yd <sup>3</sup> (0.49 m <sup>3</sup> to 1.15 m <sup>3</sup> )
Extreme-duty	24 in to 42 in (0.61 m to 1.07 m)	0.58 yd <sup>3</sup> to 1.19 yd <sup>3</sup> (0.44 m <sup>3</sup> to 0.91 m <sup>3</sup> )
Heavy-duty Coupler	24 in to 39 in (0.61 m to 0.99 m)	0.55 yd <sup>3</sup> to 1.03 yd <sup>3</sup> (0.42 m <sup>3</sup> to 0.79 m <sup>3</sup> )
Ditching	60 in to 66 in (1.52 m to 1.68 m)	1.08 yd <sup>3</sup> to 1.20 yd <sup>3</sup> (0.83 m <sup>3</sup> to 0.92 m <sup>3</sup> )

This page intentionally left blank.



NOTE: All specifications are stated in accordance with SAE Standards or Recommended Practices, where applicable.

NOTE: All engines are compliant with current EPA emissions requirements.

IMPORTANT: Case Construction Equipment Inc. reserves the right to change these specifications without notice and without incurring any obligation relating to such change. Case Construction Equipment Inc. does not warrant the safety or reliability of attachments from other manufacturers.

Case is a registered trademark of CNH America LLC. Any trademarks referred to herein, in association with goods and/or services of companies other than CNH America LLC, are the property of those respective companies.



[www.casece.com](http://www.casece.com)

